



# TURNER UNI-DRIVE

10M - MANUAL SHIFT  
10A - AUTOMATIC SHIFT

Ratio range 1.00 - 4.46 : 1  
Torque Capacity - 2220 in-lbs (Manual)  
1400 in-lbs (Automatic)

2, 3, 4, 6, and 9 speeds with manual shift  
2 or 4 speeds with automatic shift  
Off-the-shelf components for all ratios  
Available with reversing ratios

Approx. Weight 175 lbs

## DIMENSIONS

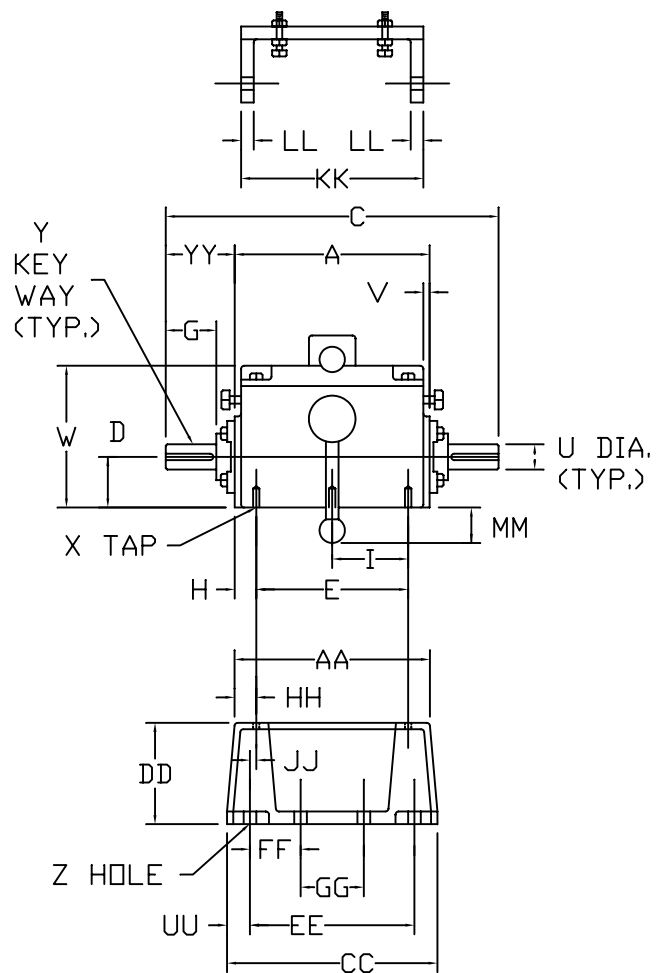
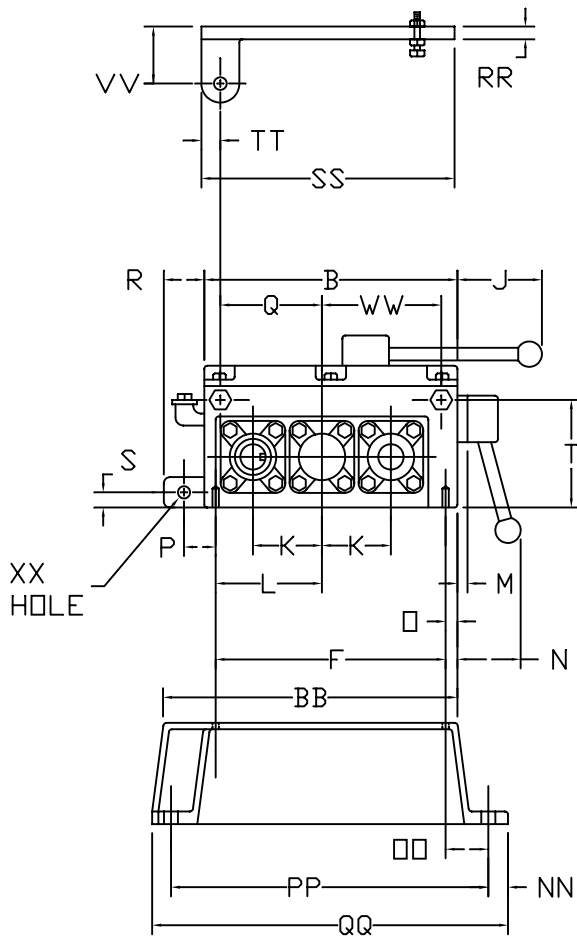

A	B	C	D	E	F	G	H	I	J	K	L	M	N	□
13 3/8	14 3/4	22 1/8	3.250	10	12 3/4	3 1/8	1 11/16	5	4	3.500	5 15/16	11/16	2 3/4	1

P	Q	R	S	T	U	V	W	X	Y	Z
2 1/4	5 7/8	2 1/4	15/32	6 3/8	1.375	21/32	8 1/8	3/8-16 THD X 5/8 DEEP	3/8 X 3/16 X 2 3/4	5/8 DIA

AA	BB	CC	DD	EE	FF	GG	HH	JJ	KK	LL	MM	NN
12	16 3/4	12 5/8	4.000	10	2 1/2	5	1	0	13 1/2	5/8	2 1/2	1 1/8

□□	PP	QQ	RR	SS	TT	UU	VV	WW	XX	YY
2 1/8	17 1/4	19 1/2	3/4	14 7/8	1 1/4	15/16	4	6 3/4	3/4 DIA	4 3/8

DIMENSIONS ARE IN INCHES AND ARE NOT TO BE USED FOR CONSTRUCTION UNLESS CERTIFIED