



TURNER UNI-DRIVE

2M - MANUAL SHIFT
2A - AUTOMATIC SHIFT

Ratio range 1.00 - 4.00 : 1
Torque Capacity - 570 in-lbs (Manual)
135 in-lbs (Automatic)

2, 3, 4, 6, and 9 speeds with manual shift
2 or 4 speeds with automatic shift
Off-the-shelf components for all ratios
Available with reversing ratios

Approx. Weight 65 lbs

DIMENSIONS

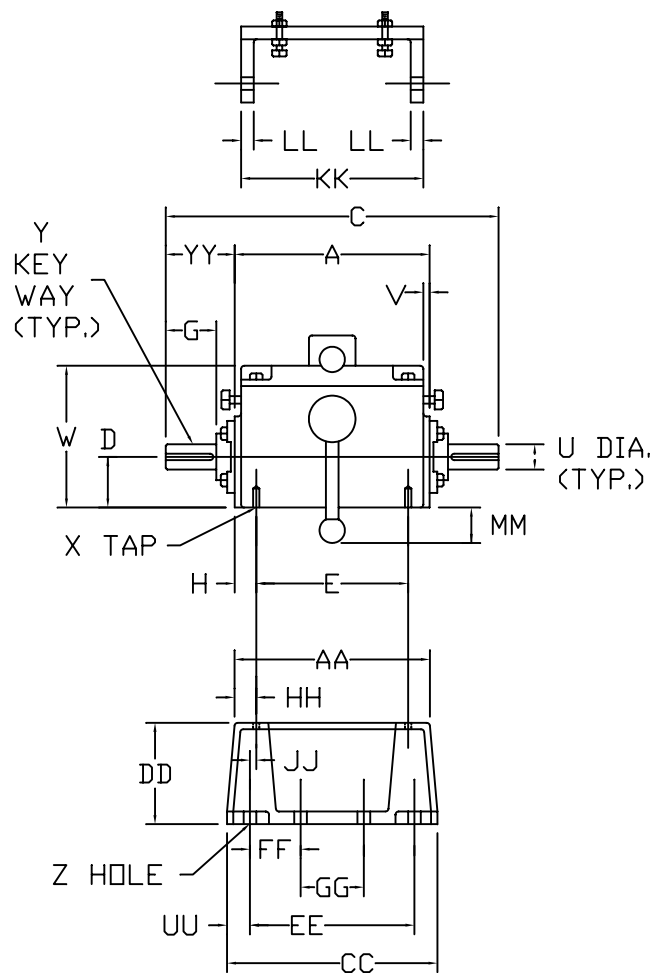
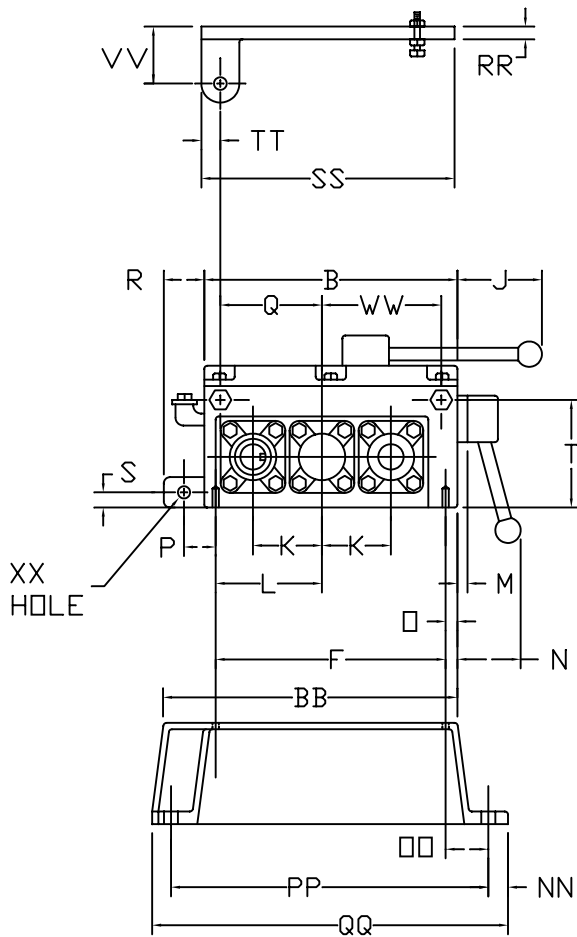

A	B	C	D	E	F	G	H	J	K	L	M	N	O
8 5/8	11 1/8	14 3/8	2.438	6 7/16	9 1/2	2 1/4	1 3/32	3 1/2	2.625	4 1/8	3/4	2 5/8	13/16

P	Q	R	S	T	U	V	W	X	Y	Z
1 5/8	4	1 3/4	3/4	4 15/16	1.000	1/4	6 7/16	3/8-16 THD X 5/8 DEEP	1/4 X 1/8 X 2	17/32 DIA

AA	BB	CC	DD	EE	FF	GG	HH	JJ	KK	LL	MM	NN
8	12 1/2	8 1/2	4.500	7	2	3	25/32	9/32	9 5/8	5/8	1 5/8	3/4

PP	QQ	RR	SS	TT	UU	VV	WW	XX	YY	
1 11/16	13	14 1/2	1/2	11	3/4	3/4	2 3/4	5 1/4	5/8 DIA	2 7/8

DIMENSIONS ARE IN INCHES AND ARE NOT TO BE USED FOR CONSTRUCTION UNLESS CERTIFIED