



TURNER UNI-DRIVE

50M - MANUAL SHIFT

Ratio range 1.00 - 4.00 : 1

Torque Capacity - 7240 in-lbs (Standard Gears)
10860 in-lbs (Special Gears)

Approx. Weight 515 lbs

2, 3, 4, and 6 speeds with manual shift
2 or 4 speeds with automatic shift
Off-the-shelf components for all ratios
Available with reversing ratios

DIMENSIONS

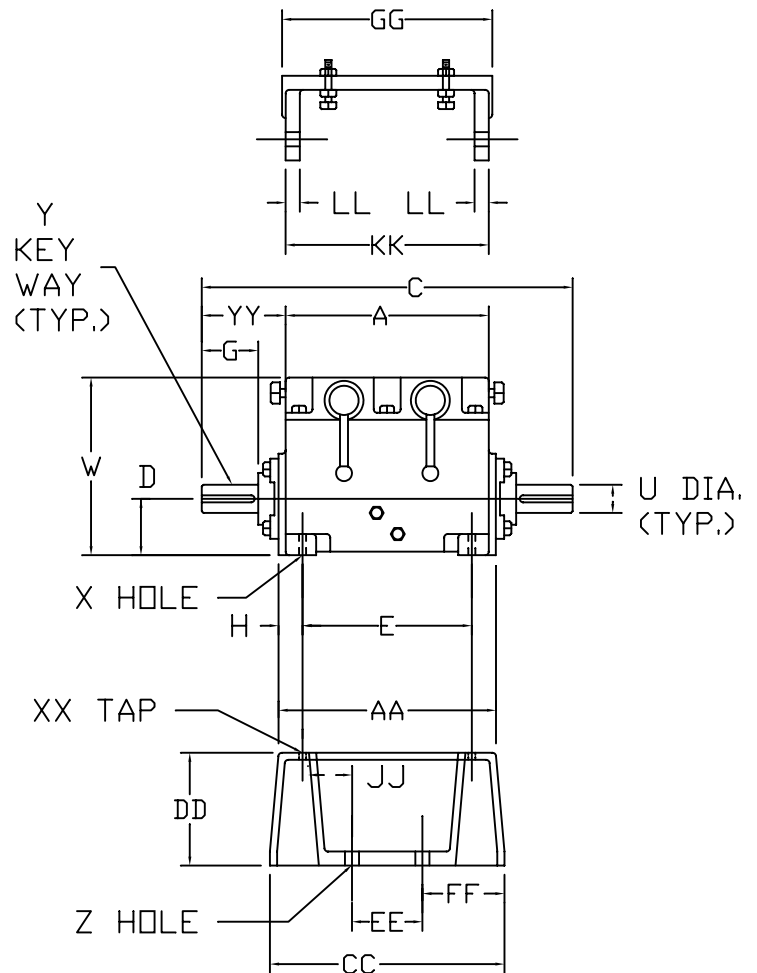
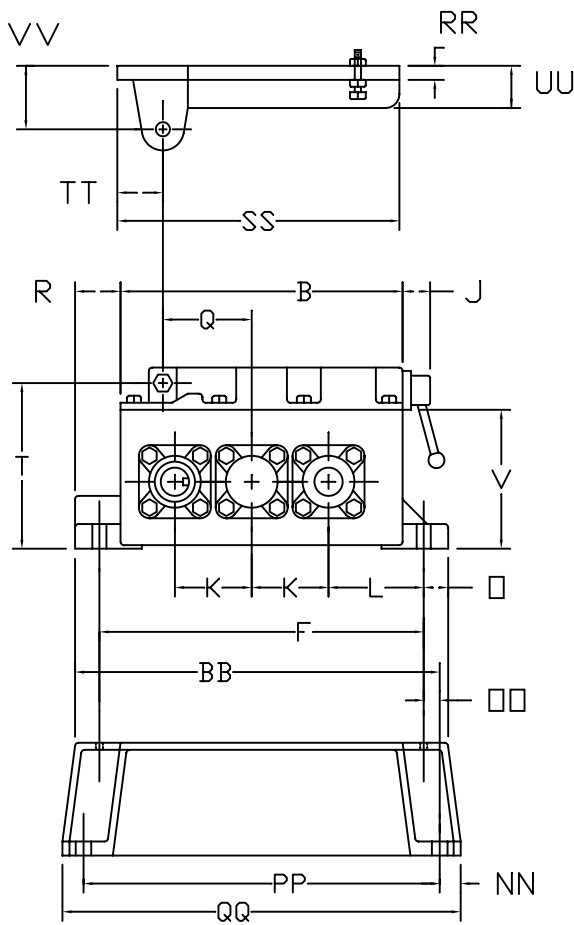

A	B	C	D	E	F	G	H	J	K	L	□
21 1/4	19 3/8	33 1/2	4.250	16 3/4	22 1/8	5	2 1/4	1 7/8	5.000	6 7/16	1 1/8

Q	R	T	U	V	W	X	Y	Z
7/16	2 1/2	10 29/32	2.250	8 29/32	11 31/32	7/8 DIA	1/2 x 1/4 x 4 1/2	7/8 DIA

AA	BB	CC	DD	EE	FF	GG	JJ	KK	LL	NN	□□
21 1/4	24 3/8	21 3/4	6.000	11 1/2	5 1/8	21 7/8	2 5/8	21 1/8	1 1/4	1 1/8	7/16

PP	QQ	RR	SS	TT	UU	VV	XX	YY
23	24 7/8	3/4	21 1/4	3 7/8	3 1/4	5	3/4-10 NC THREAD	6 1/8

DIMENSIONS ARE IN INCHES AND ARE NOT TO BE USED FOR CONSTRUCTION UNLESS CERTIFIED