



TURNER UNI-DRIVE

5M - MANUAL SHIFT
5A - AUTOMATIC SHIFT

Ratio range 1.00 - 4.84 : 1
Torque Capacity - 980 in-lbs (Manual)
650 in-lbs (Automatic)

2, 3, 4, 6, and 9 speeds with manual shift
2 or 4 speeds with automatic shift
Off-the-shelf components for all ratios
Available with reversing ratios

Approx. Weight 75 lbs

DIMENSIONS

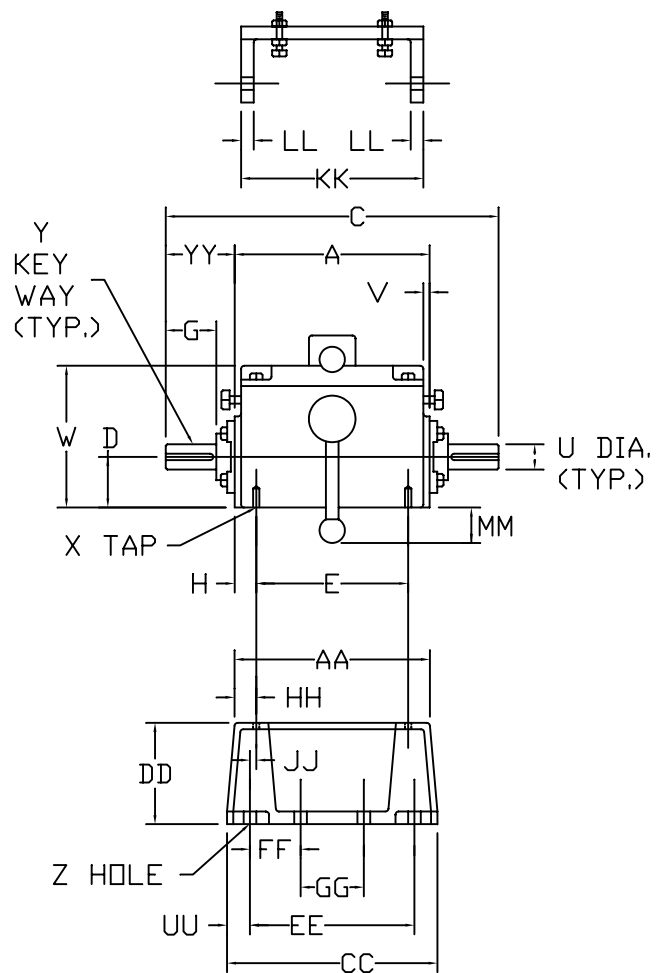
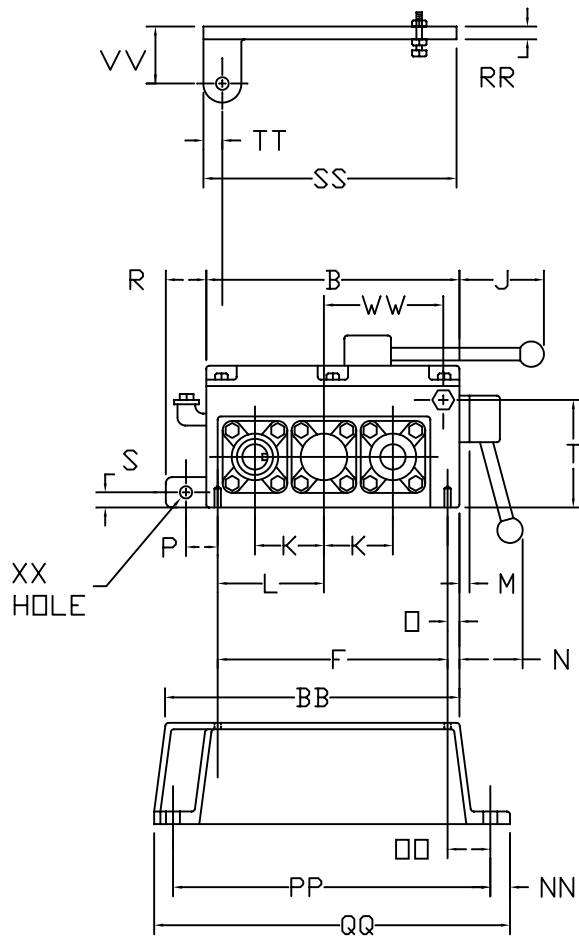

A	B	C	D	E	F	G	H	J	K	L	M	N	□
10 3/16	13 1/8	17 3/8	2.875	7 7/8	11 3/8	2 1/2	1 5/32	3 3/4	3.000	4 7/8	5/8	2 1/4	7/8

P	R	S	T	U	V	W	X	Y	Z
2	2 1/8	1 1/16	5 19/32	1.125	11/32	7 1/8	3/8-16 THD X 5/8 DEEP	3/8 X 3/16 X 2 1/4	5/8 DIA

AA	BB	CC	DD	EE	FF	GG	HH	JJ	KK	LL	MM
9 3/8	14 7/8	9 7/8	4.000	7 7/8	2 13/64	3 15/32	3/4	0	11	5/8	1 1/4

NN	□□	PP	QQ	RR	SS	TT	UU	VV	WW	XX	YY
1	2	15 3/8	17 1/2	1/2	13	7/8	1	3	6 1/4	3/4 DIA	3 19/32

DIMENSIONS ARE IN INCHES AND ARE NOT TO BE USED FOR CONSTRUCTION UNLESS CERTIFIED